

Mechanical Force Gauges

Measure tension, compression
or push/pull

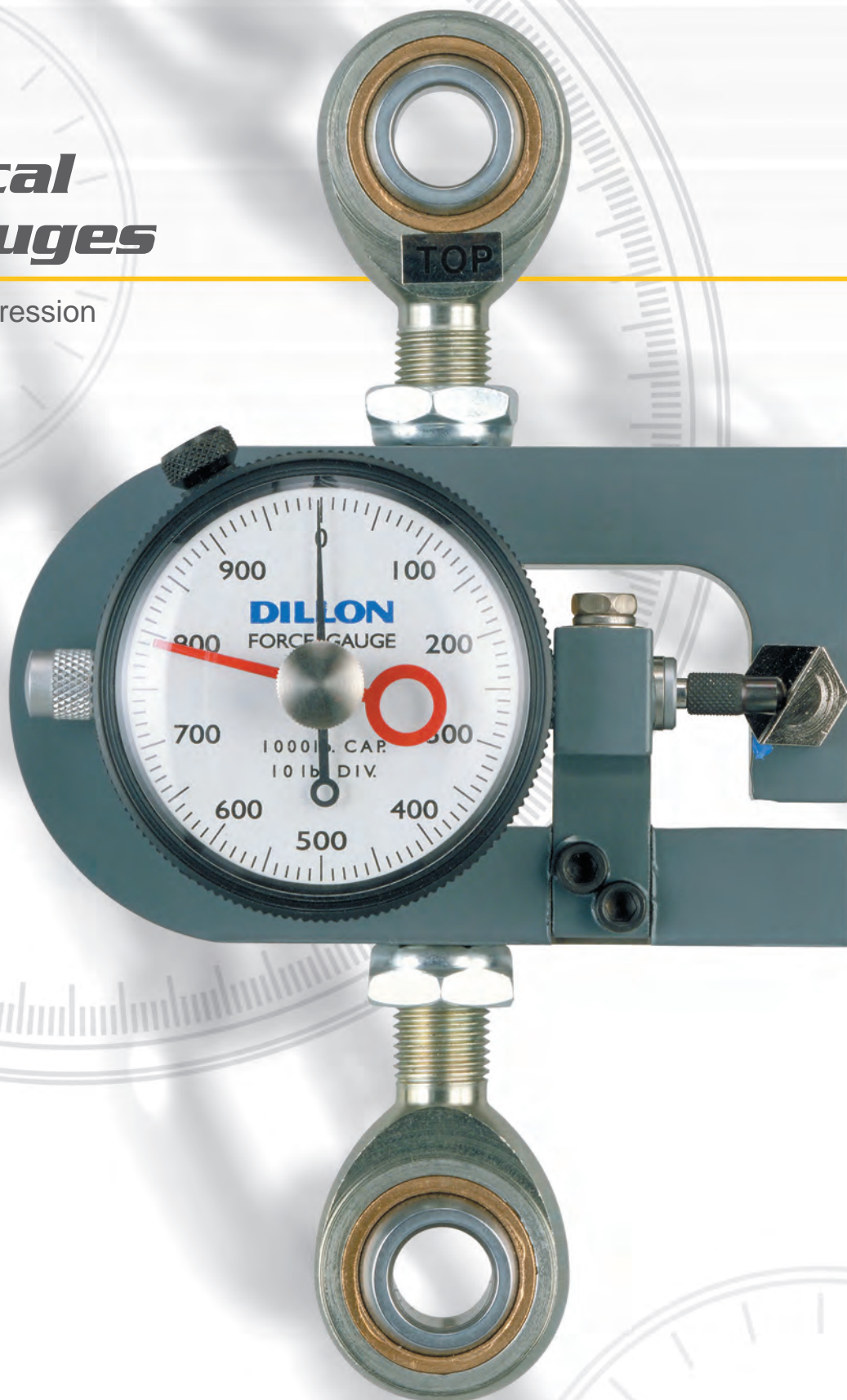

DILLON

Force Measurement Equipment

Dillon Model X Mechanical Force Gauges

Measure tension, compression and push/pull.



Model X-C with compression calibration

Model X-C comes in nine capacities ranging from 50 lb to 25,000 lb or 50 to 10000 kg. All feature accuracy of $\pm 1\%$ of full capacity, except the 25,000 (10000 kg) capacity instruments which are accurate to $\pm 2\%$ of full capacity.

Load is applied against a hardened ball which rotates to maintain vertical alignment as pressure increases. The ball is held in place with a spring clip or retainer. A threaded mounting hole is located opposite the loading ball in the bottom of the beam.

Model X-C is available in pound or kilogram capacities.



Model X-ST with tension calibration

Dillon offers the Model X-ST in seven capacities from 100 lb to 10,000 lb or 25 kg to 5000 kg. Accuracy is $\pm 1\%$ of full range. (Note: For applications requiring capacities beyond 10,000 lb or 5000 kg in tension, consider the Dillon Dynamometer).

Tension Force Gauges in capacities through 2,000 lb (1000 kg) are supplied with two rod-end connectors. 5,000 and 10,000 lb (5000 kg) capacities are equipped with convenient shackles and pins.

Calibration is available in pounds, or kilograms.



Model X-PP with compression/tension calibration

Force gauges calibrated in push-pull are available in four capacities in pounds ranging from 50-0-50 lb up to and including 2,500-0-2,500 lb and three metric capacities from 50-0-50 to 1000-0-1000 kg. Accuracy is $\pm 2\%$ of maximum dial reading (based upon total capacity of both compression and tension scales).

Model X-PP gauges in capacities up to and including 500-0-500 lb or 250-0-250 kg are supplied with a set of self-aligning spherical rod-end connectors for tension loading. Force is applied to connectors through a hardened steel pin which must be slip fit in connector holes.

2,500-0-2,500 lb and 1000-0-1000 kg capacity gauges are equipped with two shackle adapters, shackles and pins. Shackles must be removed when compression load is involved. Force is then applied against shackle pins in a suitable test setup.

All push-pull gauges are supplied with a compression-loading spherical ball fitting for compression loading.

Options

- Shockless dial indicator for installations involving the sudden application or release of force. (Maximum pointer cannot be supplied with shockless dial indicator.)
- Maximum load pointer which remains at peak load until manually reset. (not available on Model X-PP)
- Zero position on dial may be factory positioned at 12, 3, 6, or 9 o'clock. Standard position is at 12 o'clock.

Model X Force-Gauge parts identification

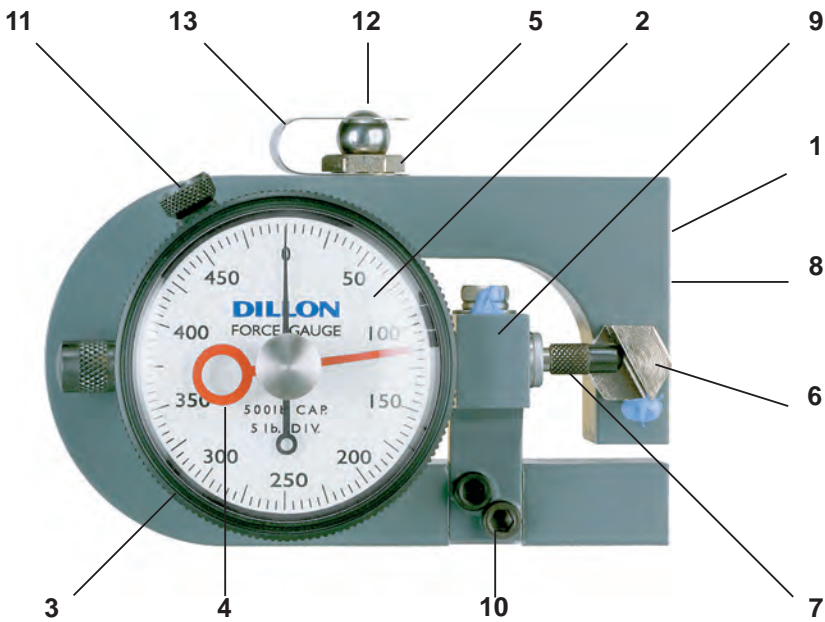

1. Deflection beam
2. Dial indicator with zero at standard 12:00 position.
3. Bezel
4. Maximum load pointer (optional)
5. Pressure button
6. Slanted Anvil
7. Dial indicator plunger
8. Anvil set screw
9. Mounting bracket for dial indicator
10. Screws for mounting bracket
11. Bezel-locking screw
12. Loading ball
13. Spring retainer clip

Principle of operation

A D-shaped deflection beam is the heart of the Dillon Force Gauge. Machined to close tolerances, beams are heat treated to develop optimum strength and spring characteristics. High-strength aluminum is used in Model X instruments through 500 lb (200 kg). Ranges above this are fabricated from aircraft-quality alloy steel.

A precision dial indicator is mounted at the null point of the deflection beam. The indicator plunger rests against a slanted anvil at the open end of the beam, as shown in the photo. Under compression loads, the two halves of the beam tend to close. Tension force causes them to move apart. This action pushes the plunger inward, as determined by the slant of the anvil. Readings produced on the dial are in direct relation to applied load. The pointer revolves 360° clockwise under compression or tension forces. Push-pull gauges read half scale (180°) clockwise in compression, and counterclockwise, 180° from center zero under tension loads.

Low beam deflection

When measured across the center of top- and bottom-loading holes, the approximate beam deflection is as follows:

50 to 250-lb capacity (25 to 100 kg)	0.019"
500-lb capacity (200 kg)	0.016"
1,000-lb capacity (500 kg)	0.018"
2,000-lb capacity (1000 kg)	0.011"
5- and 10,000-lb capacity (2 and 5000 kg)	0.010"
25,000-lb capacity (10,000 kg)	0.022"

Overload rating

Accidental overloads up to 30% of capacity can be safely sustained without injury to the dial indicator or deflection beam. All capacities feature a 5:1 design safety factor.

General information

- To reset zero, loosen knurled bezel-locking screw and rotate dial.
- Dillon Model X Force Gauges may be mounted horizontally, vertically, or flat.
- The baked-enamel finish resists corrosion and rust.
- Operating temperature up to 120° F.

Certificate of Calibration

An official Certificate of Calibration traceable to NIST, dated and signed, accompanies each new or factory serviced Dillon X Force Gauge.

A

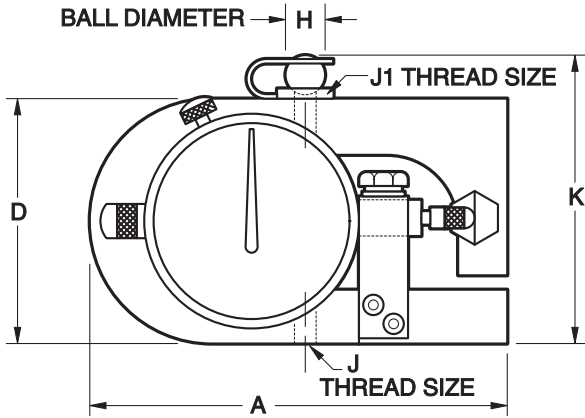

B

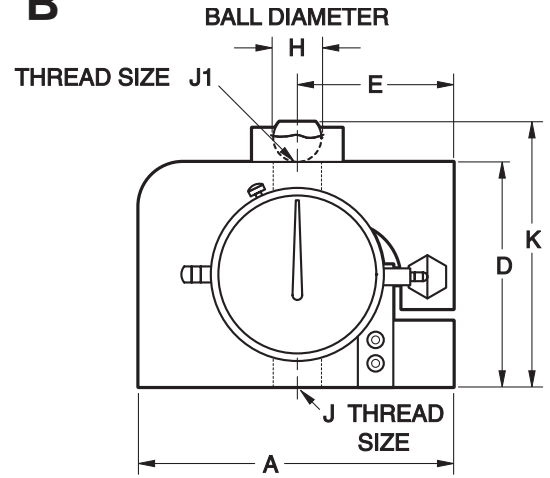

C

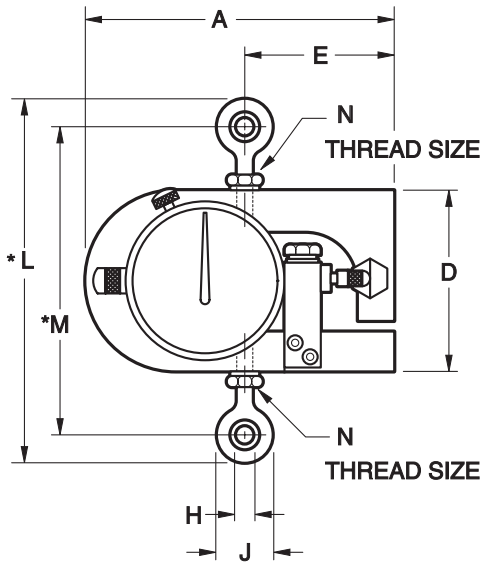

Top View of Drawings A,B,C

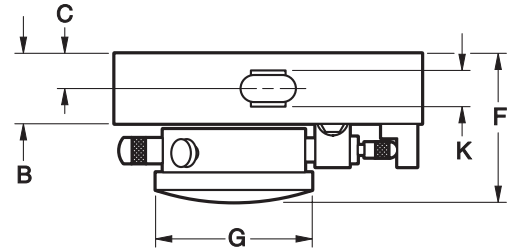

D

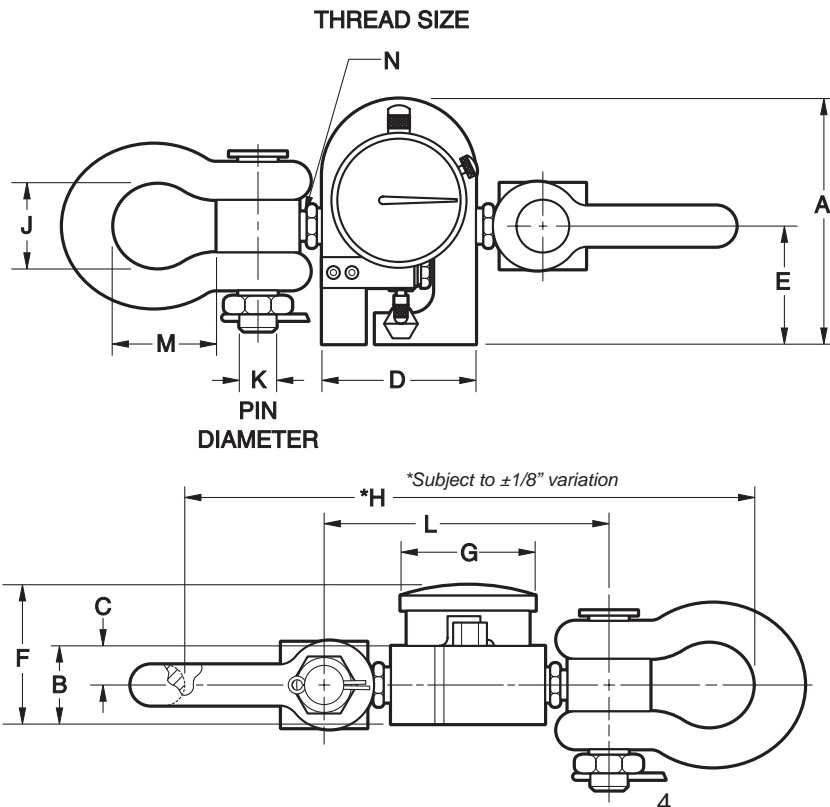

Part No.	Tension lb	Part No.	Tension kg
----	----	30443-0176*	25 x .25
30443-0044	100 x 1	30443-0093	50 x .5
30443-0150*		30443-0184*	
30445-0034	250 x 2.5	----	100 x 1
30445-0109*		30445-0182*	
30445-0018	500 x 5	30445-0026	200 x 2
30445-0083*		30445-0091*	
30276-0012	1,000 x 10	----	500 x 5
30276-0053*		30276-0061*	
30440-0013	2,000 x 20	----	1000 x 10
30440-0054*		30440-0062*	
----	5,000 x 50	----	2000 x 20
30442-0052*			
----	10,000 x 100	----	5000 x 50
30441-0053*		30441-0061*	

* with max hand

Model X-C (Compression) Force Gauge

Part No.	Pounds	Part No.	Kilograms	A	B	C	D	E	F	G	H	J	J1	K
				in. (mm)	in. (mm)	in. (mm)	in. (mm)	in. (mm)	in. (mm)	in. (mm)	in. (mm)	in. (mm)	in. (mm)	in. (mm)
A 30386-0035	50 x .5	----	----	4.25 (107.9)	1.00 (25.4)	.50 (12.7)	2.50 (63.5)	2.06 (52.3)	2.00 (50.8)	2.25 (57.1)	.38 (9.6)	1/4-28	1/4-28	2.94 (74.6)
30386-0043 30386-0159*	100 x 1	----	50 x .5	4.25 (107.9)	1.00 (25.4)	.50 (12.7)	2.50 (63.5)	2.06 (52.3)	2.00 (50.8)	2.25 (57.1)	.38 (9.6)	1/4-28	1/4-28	2.94 (74.6)
30446-0033 30446-0090*	250 x 2.5	----	100 x 1	4.25 (107.9)	1.00 (25.4)	.50 (12.7)	2.50 (63.5)	2.06 (52.3)	2.00 (50.8)	2.25 (57.1)	.38 (9.6)	1/4-28	1/4-28	2.94 (74.6)
30446-0017 30446-0074*	500 x 5	----	200 x 2	4.25 (107.9)	1.00 (25.4)	.50 (12.7)	2.50 (63.5)	2.06 (52.3)	2.00 (50.8)	2.25 (57.1)	.38 (9.6)	1/4-28	1/4-28	2.94 (74.6)
30444-0019 30444-0050*	1,000 x 10	----	500 x 5	4.25 (107.9)	1.00 (25.4)	.50 (12.7)	2.50 (63.5)	2.06 (52.3)	2.00 (50.8)	2.25 (57.1)	.38 (9.6)	1/2-20	1/2-20	2.94 (74.6)
30388-0017 30388-0058*	2,000 x 20	----	1000 x 10	4.75 (120.6)	1.00 (25.4)	.50 (12.7)	3.00 (76.1)	2.25 (57.1)	2.50 (63.5)	2.75 (69.8)	.38 (9.6)	1/2-20	1/2-20	3.44 (87.3)
30389-0016 30389-0057*	5,000 x 50	----	2000 x 20	4.75 (120.6)	1.00 (25.4)	.50 (12.7)	3.00 (76.1)	2.25 (57.1)	2.50 (63.5)	2.75 (69.8)	.38 (9.6)	1/2-20	1/2-20	3.44 (87.3)
B 30423-0014 30423-0055*	10,000 x 100	----	5000 x 50	5.87 (149.0)	1.87 (47.5)	.94 (23.9)	3.94 (100.0)	2.75 (69.8)	3.00 (76.1)	3.62 (91.9)	.75 (19.0)	7/8-14	7/8-14	4.50 (114.2)
30449-0014 30449-0055*	25,000 x 250	----	10000 x 100	6.56 (166.5)	2.38 (60.4)	1.18 (29.9)	4.68 (118.8)	3.31 (84.0)	3.63 (92.1)	3.62 (91.9)	1.00 (25.4)	1-14	1 1/4-12	5.50 (139.6)

* with max hand

Model X-ST (Tension) and Model X-PP (Push-Pull) Gauges

Part No.	Push-Pull lb	Part No.	Push-Pull kg	A	B	C	D	E	F	G	H	J	K	L	M	N
				in. (mm)	in. (mm)	in. (mm)	in. (mm)	in. (mm)	in. (mm)	in. (mm)	in. (mm)	in. (mm)	in. (mm)	in. (mm)	in. (mm)	in. (mm)
----	----	----	----	4.25 (107.9)	1.00 (25.4)	.50 (12.7)	2.50 (63.5)	2.06 (52.3)	2.03 (51.5)	2.25 (57.1)	.25 (6.3)	.75 (19.0)	.38 (9.6)	5.00	4.25 (107.9)	1/4-28
30795-0014	50-0-50	----	----	4.25 (107.9)	1.00 (25.4)	.50 (12.7)	2.50 (63.5)	2.06 (52.3)	2.03 (51.5)	2.25 (57.1)	.25 (6.3)	.75 (19.0)	.38 (9.6)	5.00	4.25 (107.9)	1/4-28
30796-0013	125-0-125	30796-0021	50-0-50	4.25 (107.9)	1.00 (25.4)	.50 (12.7)	2.50 (63.5)	2.06 (52.3)	2.03 (51.5)	2.25 (57.1)	.25 (6.3)	.75 (19.0)	.38 (9.6)	5.00	4.25 (107.9)	1/4-28
----	----	----	----	4.25 (107.9)	1.00 (25.4)	.50 (12.7)	2.50 (63.5)	2.06 (52.3)	2.03 (51.5)	2.25 (57.1)	.25 (6.3)	.75 (19.0)	.38 (9.6)	5.00	4.25 (107.9)	1/4-28
30798-0011	500-0-500	----	----	4.25 (107.9)	1.00 (25.4)	.50 (12.7)	2.50 (63.5)	2.06 (52.3)	2.03 (51.5)	2.25 (57.1)	.50 (12.7)	1.31 (33.2)	.62 (15.7)	6.94	5.62 (155.3)	1/2-20
----	----	----	----	4.75 (120.6)	1.00 (25.4)	.50 (12.7)	3.00 (76.1)	2.25 (57.1)	2.19 (55.6)	2.75 (69.8)	.50 (12.7)	1.31 (33.2)	.62 (15.7)	7.44	6.12 (155.3)	1/2-20
30800-0017	2,500-0-2,500	30800-0025	1000-0-1000	4.75 (120.6)	1.50 (38.1)	.75 (19.0)	3.00 (76.1)	2.25 (57.1)	2.66 (67.5)	2.75 (69.8)	10.94 (277.7)	1.69 (42.9)	.75 (19.0)	5.44	1.94 (138.1)	1/2-20
----	----	----	----	5.88 (149.2)	1.88 (47.7)	.94 (23.9)	3.94 (100.0)	2.75 (69.8)	3.00 (76.1)	3.62 (91.9)	12.69 (322.1)	1.69 (42.9)	.75 (19.0)	7.19	1.94 (182.5)	7/8-1/4

Dillon Model U Force Gauges

Slim line design for added versatility.

The Model U Force Gauge is an accurate ($\pm 1\%$ of full range) mechanical compression-measurement instrument. Its slim-line design has repeatedly proven valuable in installations where space is at a premium.

The versatility of this simple instrument is demonstrated by the fact that it can be used as a hand-held device, permanently mounted on a flat surface plate, or used in test fixtures.

How the U Force Gauge Works

The Dillon Model U Force Gauge employs a deflection beam machined from aircraft quality alloy steel and heat treated to develop optimum strength and spring characteristics. A precision dial indicator is mounted at the null point of this beam.

Compression force is normally applied against a single pressure fitting mounted on the upper half of the beam. (For accurate calibration, designate the type of pressure fitting you wish to use with the U Force Gauge. They are of four types: domed, cupped, flat, or a flat nylon insert. Flat bottom gauges require only one fitting).

When load is exerted, the beam moves downward causing a slanted anvil on the free end to push against the indicator plunger. The indicator reading is a direct representation of the applied load.

Dillon offers a capacity for every job

U Force Gauges are available for measurement in pounds or kilograms. There are 6-pound capacities ranging from 25 x .25 to 5,000 x 50 lb. The 4 kilogram capacities range from 10 x .1 to 500 x 5 kg.

Dillon also offers high-capacity gauges with pounds capacities from 500 to 5,000 lb and a metric model with a capacity of 500 kg. High-capacity gauges all have flat-bottom design.

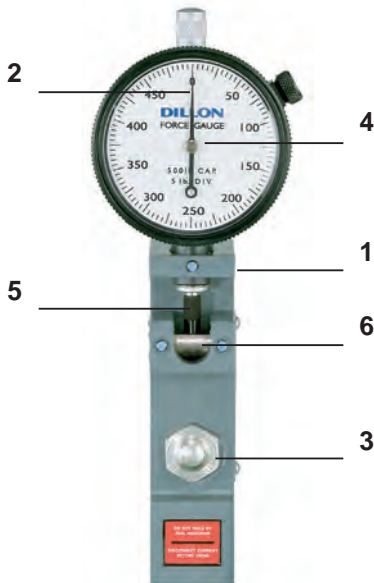

1. Deflection beam
2. Indicator with zero at 6:00 position
3. Pressure fitting
4. Maximum pointer (optional)
5. Indicator plunger
6. Slanted anvil

Options



Zero position—The zero position on the indicator dial can be factory positioned at 12 o'clock, 3 o'clock, 6 o'clock, or 9 o'clock. The standard position is the 6 o'clock position.

Maximum pointer—Model U Force Gauges can include a maximum pointer which remains at peak load until it is reset.

Shockless dial indicator—Offers added protection in applications where force is applied or released rapidly.

Dial orientation—The dial indicator can be factory positioned at 0° (standard), 90°, 180°, 270° clockwise. Photos on this page show standard dial orientation.

Note: maximum pointer and shockless dial indicator cannot be offered on the same unit.

Certificate of Calibration

An official Certificate of Calibration traceable to NIST, dated and signed, accompanies each new or factory serviced Dillon U Force Gauge.

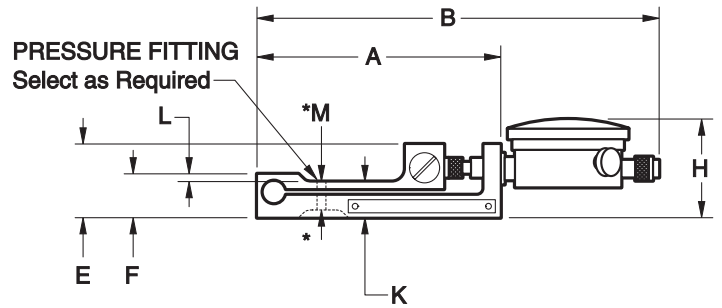
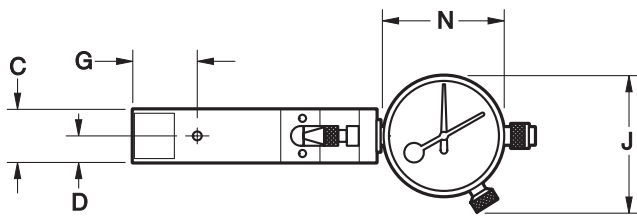

Low-Range Flat-Bottom Model U Force Gauge

Part No.	Pounds	Part No.	Kilograms	A	B	C	D	E	F	G	H	J	K	L	M
				in. (mm)	in. (mm)	in. (mm)	in. (mm)	in. (mm)	in. (mm)	in. (mm)	in. (mm)	in. (mm)	in. (mm)	in. (mm)	in. (mm)
30354-0017	25 x .25	30354-0066	10 x .1	3.28 (83.3)	5.50 (139.6)	.73 (18.5)	.36 (9.1)	.97 (24.6)	.56 (14.2)	.90 (22.8)	1.40 (35.5)	1.87 (47.5)	.46 (11.7)	.094 (2.4)	1.67 (42.4)
30354-0033	100 x 1	30354-0082	50 x .5	3.28 (83.3)	5.50 (139.6)	.73 (18.5)	.36 (9.1)	.97 (24.6)	.56 (14.2)	.90 (22.8)	1.40 (35.5)	1.87 (47.5)	.46 (11.7)	.094 (2.4)	1.67 (42.4)
30354-0058	250 x 2.5	30354-0090	100 x 1	3.28 (83.3)	5.50 (139.6)	.73 (18.5)	.36 (9.1)	.97 (24.6)	.56 (14.2)	.90 (22.8)	1.40 (35.5)	1.87 (47.5)	.46 (11.7)	.094 (2.4)	1.67 (42.4)

Also available in newton calibration

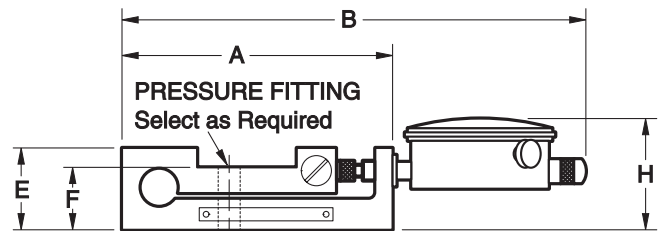
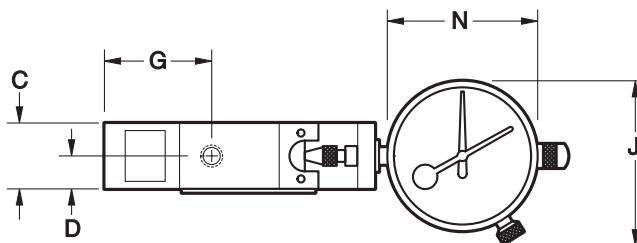

High-Range Flat Bottom Model U Force Gauge

Part No.	Pounds	Part No.	Kilograms	A	B	C	D	E	F	G	H	J	N
				in. (mm)	in. (mm)	in. (mm)	in. (mm)	in. (mm)	in. (mm)	in. (mm)	in. (mm)	in. (mm)	in. (mm)
30482-0020	500 x 5	----	----	3.87 (98.0)	6.75 (171.3)	.98 (24.9)	.49 (12.4)	1.25 (31.5)	.92 (23.6)	1.52 (38.6)	1.67 (42.4)	2.44 (63.5)	2.25 (57.2)
30482-0053	1,000 x 10	30482-0079	500 x 5	3.87 (98.0)	6.75 (171.3)	.98 (24.9)	.49 (12.4)	1.25 (31.5)	.92 (23.6)	1.52 (38.6)	1.67 (42.4)	2.44 (63.5)	2.25 (57.2)
30478-0034	5,000 x 50	----	----	4.74 (120.1)	7.94 (201.5)	.98 (24.9)	.49 (12.4)	1.72 (43.7)	1.41 (35.5)	2.06 (52.3)	2.06 (52.3)	2.88 (72.8)	2.75 (69.9)

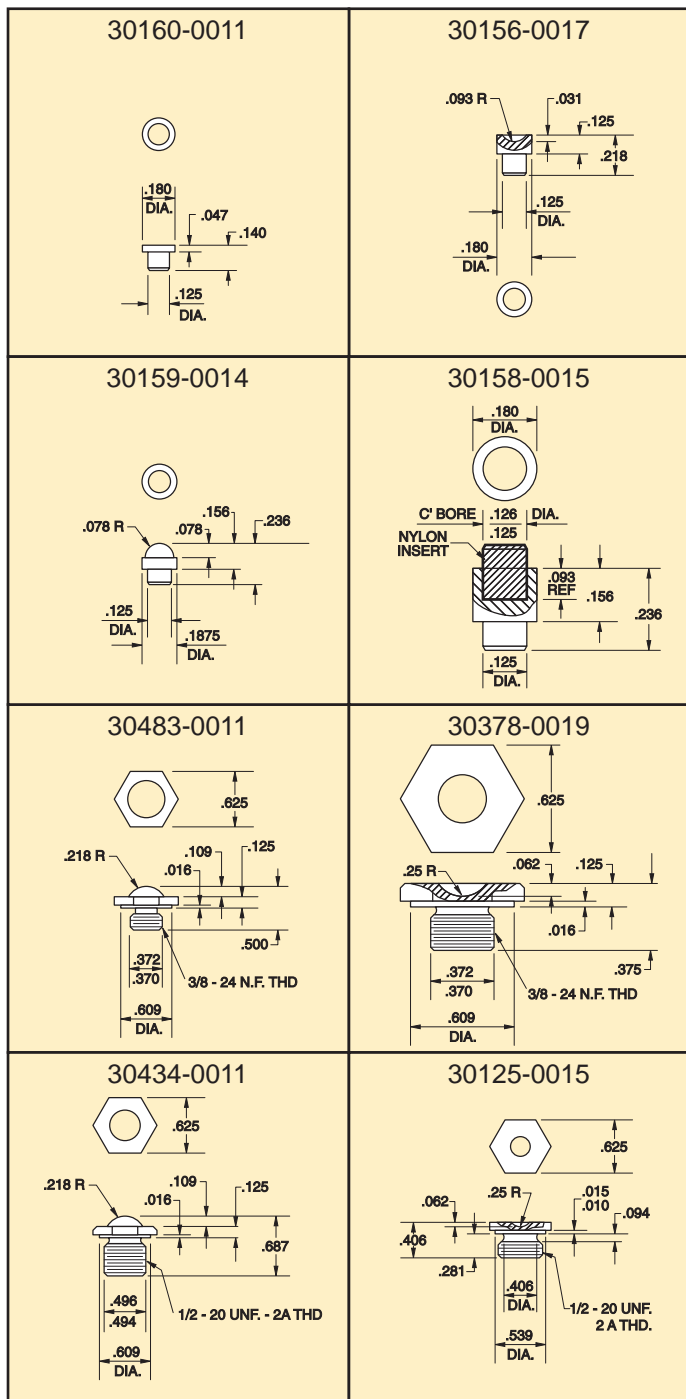

Select the right pressure fittings

Load is applied to the Dillon Model U Force Gauge through hardened pressure fittings.

Replacement fittings for recessed-bottom - two fittings
Flat-bottom - one fitting

Fittings are not included. Choose fittings from the below list.

For 25 to 250 lb (10 to 100 kg) capacity gauges:

- Part No. 30160-0011 flat surface
- Part No. 30156-0017 cupped surface
- Part No. 30159-0014 domed surface
- Part No. 30158-0015 nylon insert

For 500 lb, 1000 lb, and 500 kg capacity gauges:

- Part No. 30483-0011 domed surface
- Part No. 30378-0019 cupped surface
- Part No. 30484-0010 flat surface

For 5,000 lb capacity gauges:

- Part No. 30434-0011 domed surface pressure fitting
- Part No. 30125-0015 cupped surface pressure fitting
- Part No. 30475-0011 flat surface

AUTHORIZED DISTRIBUTORS

Ask the experts. Dillon distributors offer complete service capabilities from application assistance to sales and product support. Their experienced representatives are the most knowledgeable experts that you will find in the force measurement industry. We recommend that you consult these capable specialists for all of your measuring needs.

DILLON USA

1000 Armstrong Drive
Fairmont, MN 56031

Toll-Free: (800) 368-2031

Phone: (507) 238-8796

Fax: (507) 238-8258

www.dillonforce.com

DILLON UK

Foundry Lane, Smethwick,
West Midlands B66 2LP

Phone: +44 (0) 845 246 6717

Fax: +44 (0) 845 246 6718

Email: sales@dillon-force.co.uk

www.dillon-force.co.uk

DILLON

Force Measurement Equipment

A division of Avery Weigh-Tronix, LLC



Dillon is part of Avery Weigh-Tronix. Avery Weigh-Tronix is a trademark of the Illinois Tool Works group of companies whose ultimate parent company is Illinois Tool Works Inc ("Illinois Tool Works"). Copyright © 2018 Illinois Tool Works. All rights reserved. This publication is issued to provide outline information only and may not be regarded as a representation relating to the products or services concerned. This publication was correct at the time of going to print, however Avery Weigh-Tronix reserves the right to alter without notice the specification, design, price or conditions of supply of any product or service at any time.